

INSTALLATION INSTRUCTIONS

13.520 - ST MIDI (6mm x 90mm)

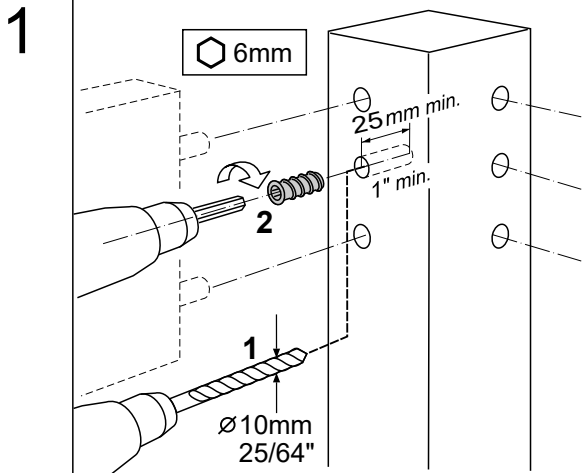

After marking the centre hole for the insert screw, bore a 25/64" (10mm) perpendicular hole - for hardwoods the hole can be larger and wax is recommended. Use an 6mm hex bit or Allen key to drive in the insert.

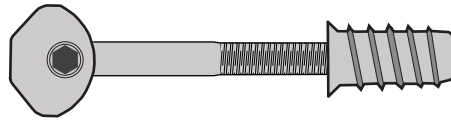
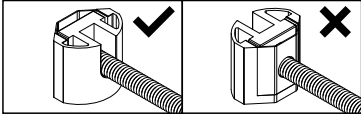
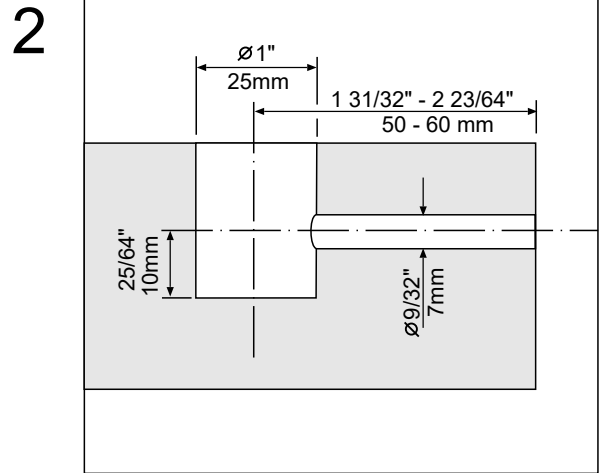

Bore the railing according to recommended diameters and distances, depending on the rail thickness the connectors can be set deeper into the material.

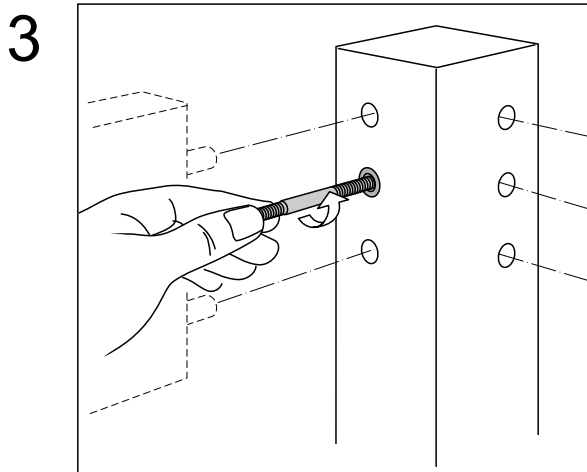

Install the screw shaft into the insert screw counter clockwise.

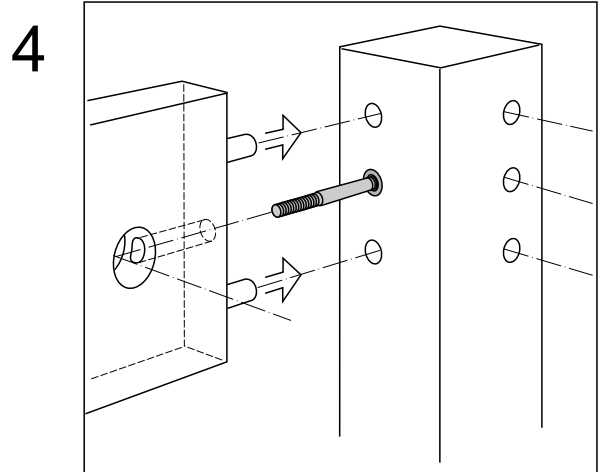

Push the joint together.

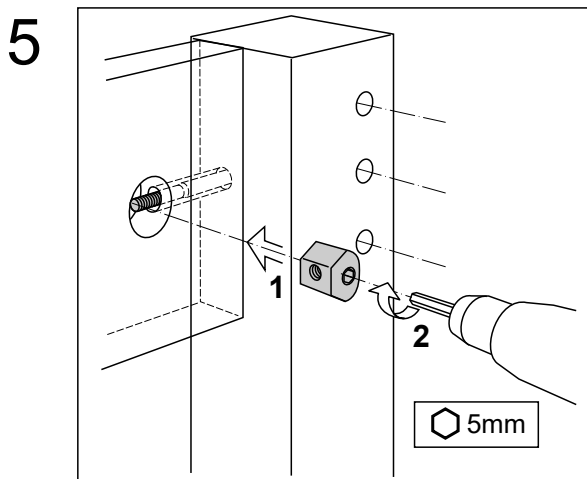

Place the gear housing onto the screw shaft thread, tighten with a 5mm hex bit in a power drill or with a hand driver.

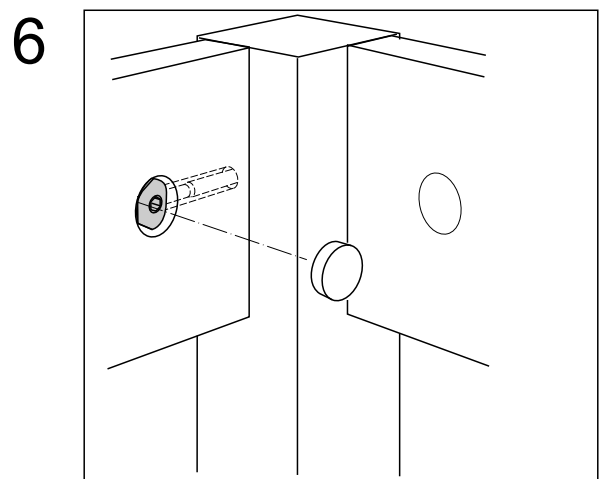

Once completed the 1" (25mm) hole can be plugged / this is optional.