

INSTALLATION INSTRUCTIONS

Zipbolt Super UT Post Fastener into CONCRETE

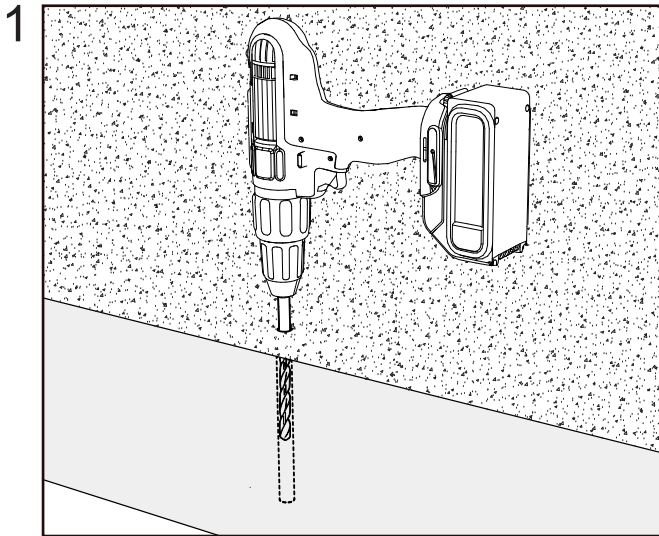

Bore the hole into the concrete slightly larger than the external steel thread, taking note of the depth required.

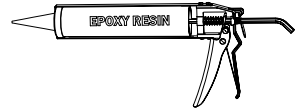
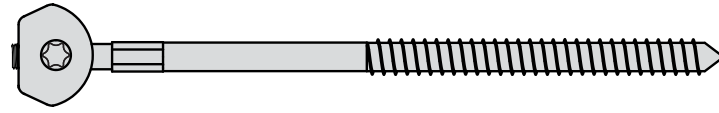
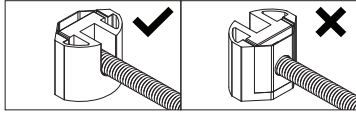
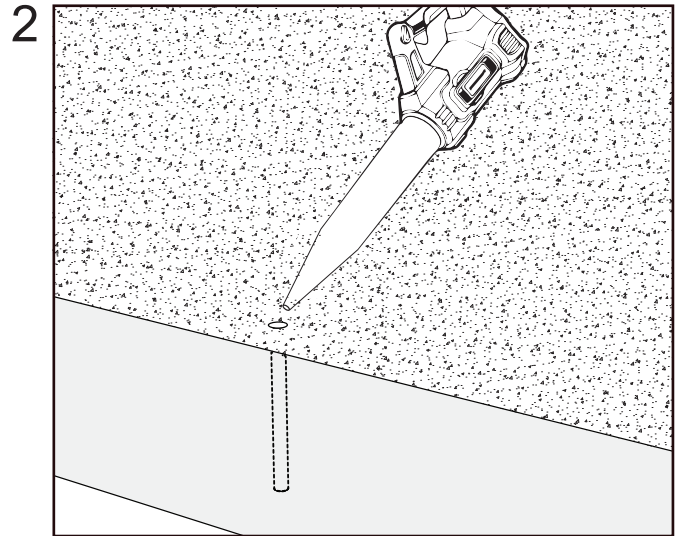

Blow or vacuum dust out of the hole.

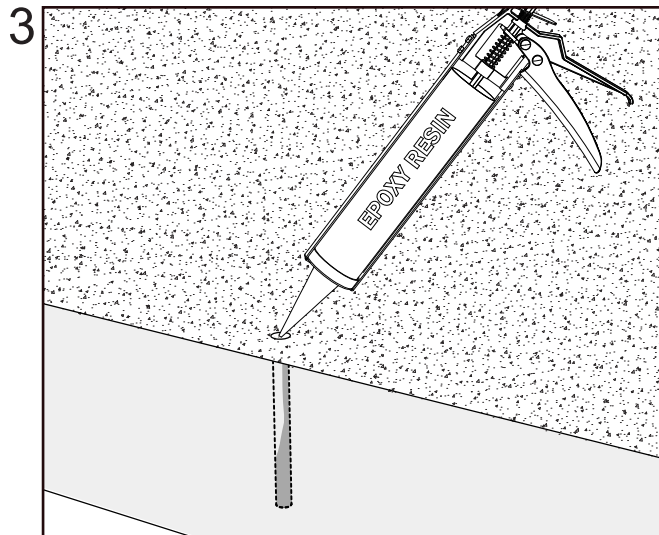

Fill hole $\frac{1}{3}$ to $\frac{1}{2}$ with epoxy resin.

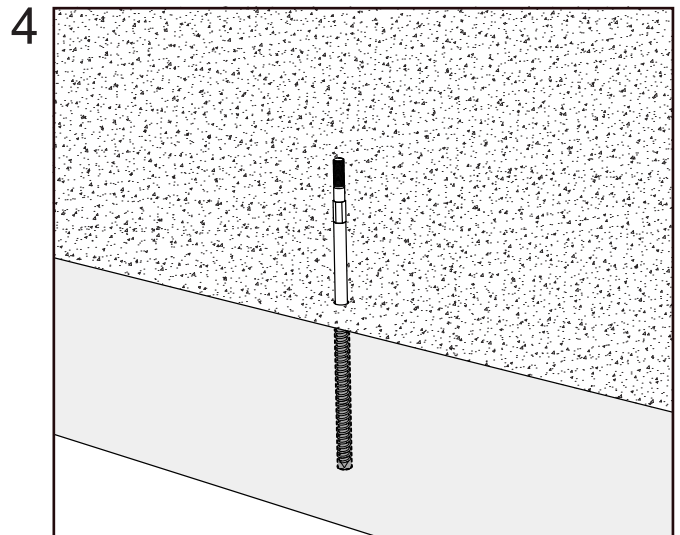

Set shaft at correct height and wipe off excess epoxy. Allow to set.

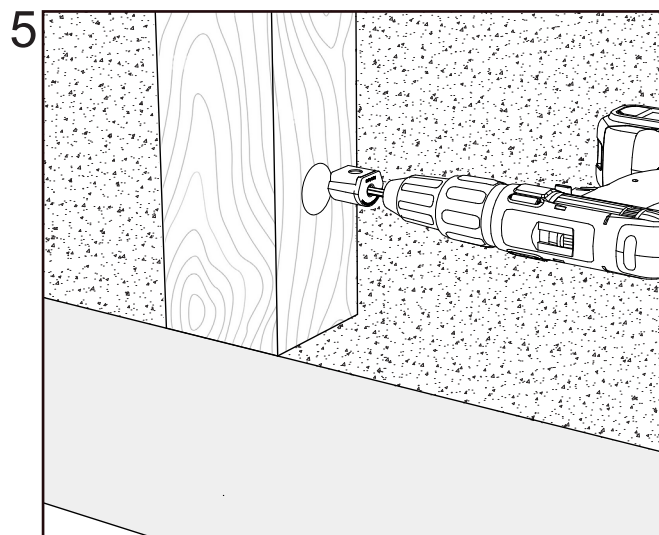

Assemble post using Zipbolt gear housing.

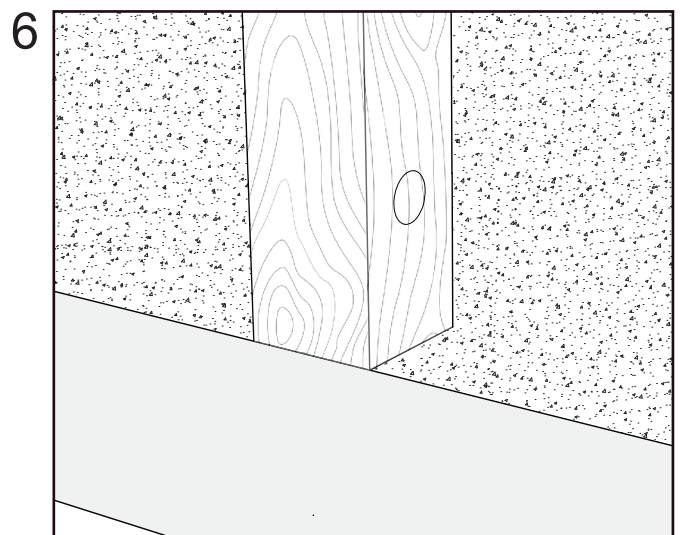

Plug hole, job complete.