

### A Template for Joining Rail to Fitting using Rail Cutoff

#### 1. Prep Work

**1. Preparing a template**  
Make a template by cutting a  $\frac{3}{16}$ " (5mm) wafer from the appropriate hand rail.

Measure on the centreline  $\frac{15}{16}$ " (24mm) from the bottom of the rail. Drill a  $\frac{1}{16}$ " (2mm) diameter hole as shown in figure 1.

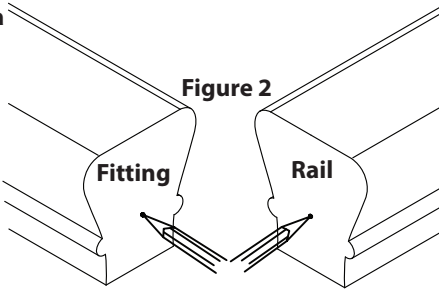
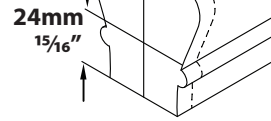

Figure 1



**2. Using the template** write rail on one side of the template and fitting on the other side. Align the template. Mark the rail and fitting as shown in figure 2.

### Drilling Rail and Fitting - Joining with Rail Bolt Assembly - Installing Hole Plug



Railbolt Drillguide available

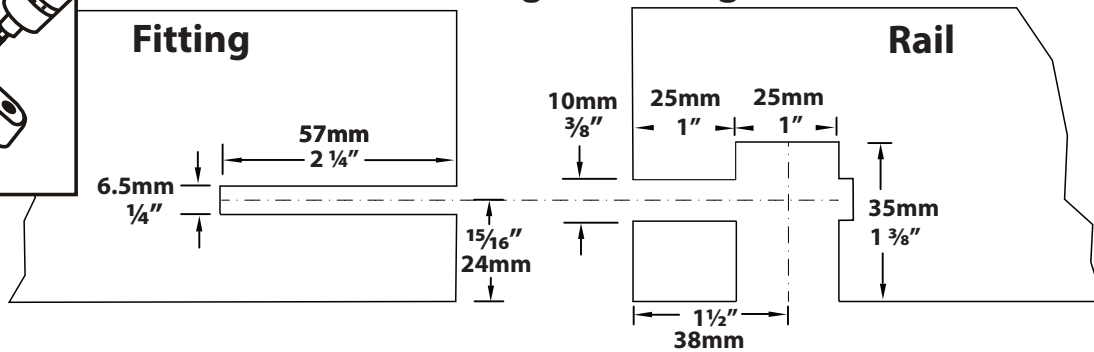

#### 2. Installation

1. Drill correct diameter hole in fitting  $2 \frac{1}{4}$ " (57mm) deep in location marked by template (see prep section).
2. Drill a 1" (25mm) diameter in bottom of rail on centerline,  $1 \frac{1}{2}$ " (38mm) from end of rail. Hole should pass into 1" (25mm) hole.
3. Using mark made with template (see figure 2) drill a  $\frac{3}{8}$ " (10mm) diameter hole in end of rail. Hole should be  $1 \frac{1}{2}$ " (38mm) deep.
4. Install rail bolt in fitting with  $1 \frac{7}{8}$ " (48mm) of bolt protruding (**Zipbolt 40.520 Deep Socket available**)
5. Assemble rail and fitting dry to check fit using 5mm HEX. Use glue on final assembly. Apply glue to edges of plug and cover 1" (25mm) diameter hole in bottom of rail. Sand smooth.

#### 3. Specifications

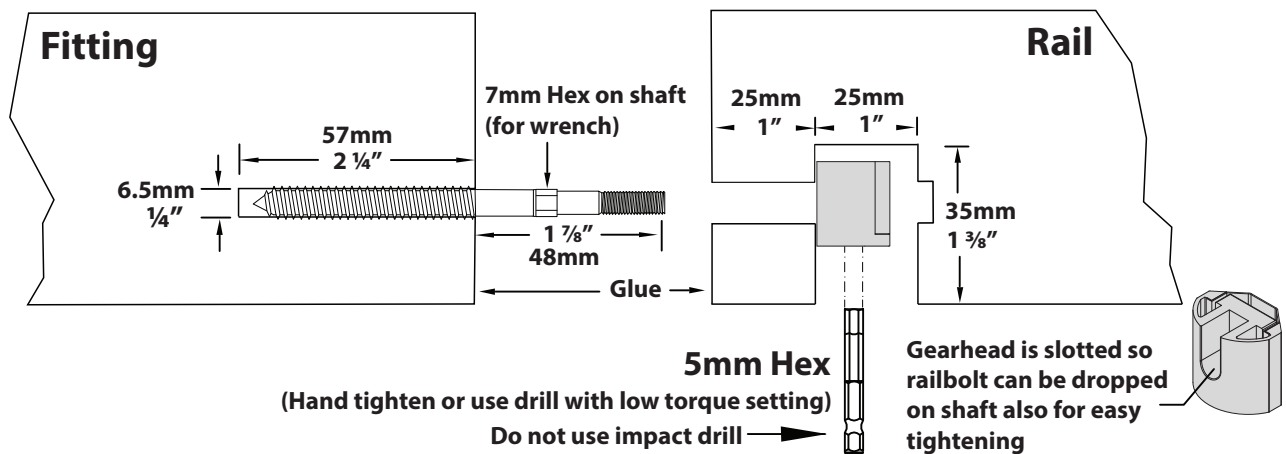

#### 4. Cross Section

