

## SPECIFICATION

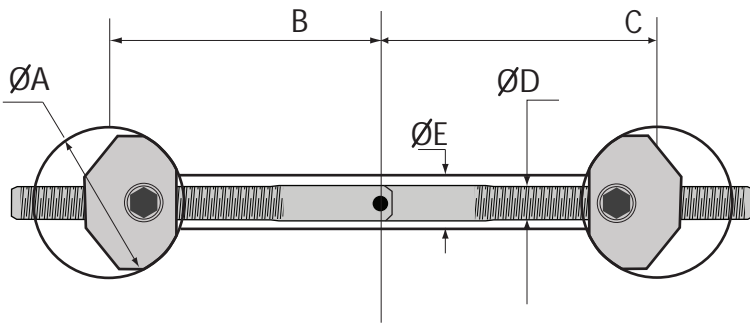

### SHAFT CENTRE CALCULATION

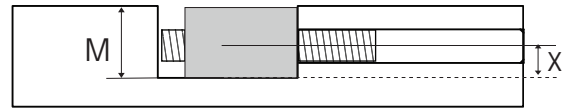

M= Minimum Bore Depth 12.5mm (31/64 inches)  
 X = Shaft Centre 5.5mm (13/64 inches)

## Measurements

	Millimetres	Inches
A	25	1
B	60*	2 <sup>23</sup> / <sub>64</sub>
C	60*	2 <sup>23</sup> / <sub>64</sub>
D	6	1 <sup>5</sup> / <sub>64</sub>
E	7	9/ <sub>32</sub>



**\*Note:** The distance from edge of the material to the centre of the 25mm diameter bore hole(A) is 60mm (B). Depending on the angle the material is cut and the depth of the bore hole, this actual distance will vary. The MITRE ZPBOLT has been designed to be adjusted on the full scope of threaded shaft. For further adjustment when drilling the 7mm shaft (E) continue to drill past the 25mm bore hole. This allows the shaft to travel further past the gear head when tensioning MITRE Zipbolt.

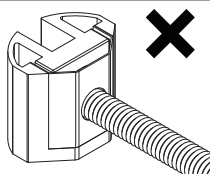
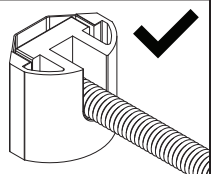

**BEST** ✓

TO TIGHTEN GEAR BY HAND  
 OR WITH A DRILL ON LOW  
 TORQUE SETTING



**NEVER** ✗

USE IMPACT DRIVER TO  
 TIGHTEN GEAR



Art. 11.700

## MINI UT 90 - 180°, Gehrungsverbinder

Weiterentwicklung des bewährten ZIPBOLT-Antriebs

- Ganzmetallausführung
- Schnell/Robust/Einfach
- Großer Toleranzausgleich
- **Spannbereich >5 mm**
- **Für dünne Böden ab ca. 13,5 mm**
- Für Gehrungen von 90 - 180°

Inklusive Gehrungsbolzen 90-180° / M6\*

\*Eindreihen der Bolzen entgegen Uhrzeigersinn (Linksgewinde), damit der Verbinder wie gewohnt im Uhrzeigersinn angezogen werden kann.

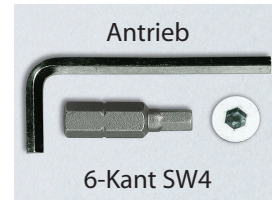
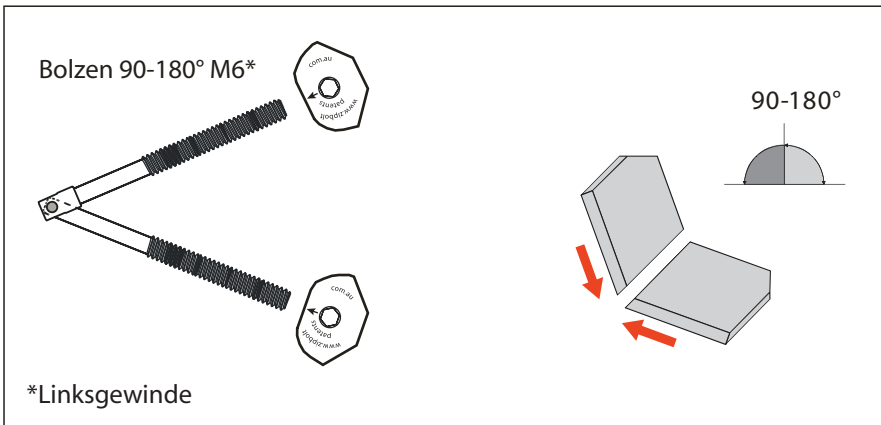

max. 10 Nm

Verbinder bitte gleichmäßig und abwechselnd anziehen.

Zum Lösen der Verbindung bitte die einzelnen Verbinder schrittweise und abwechselnd wieder lösen.

## Bohrmaße Art. 11.700

